

THANK YOU FOR CHOOSING PANELTRONICS, INC. THIS WIRING DIAGRAM WILL ADVISE YOU IN THE INSTALLATION OF YOUR NEW PANEL. IT SHOULD BE KEPT FOR FUTURE REFERENCE AND SERVICE TO THE ELECTRICAL CONTROL PANEL. WITH PROPER MAINTENANCE, YOU WILL ENJOY MANY YEARS OF RELIABLE OPERATION.

ALL PANELTRONICS PRODUCTS SHOULD BE USED AND INSTALLED IN ACCORDANCE WITH THE PROVISIONS OF THE NATIONAL ELECTRIC CODE, U.L. AND OTHER LOCAL, MILITARY OR INDUSTRIAL STANDARDS THAT ARE PERTINENT TO THE PARTICULAR END USE. IN MARINE INSTALLATIONS, ALL PANELS MUST BE INSTALLED TO MEET THE REQUIREMENTS OF U.S.C.G. 33CFR SUBPART 1, ELECTRICAL SYSTEMS, ON ALL BOATS THAT HAVE GASOLINE ENGINES FOR ELECTRICAL OR MECHANICAL POWER OR PROPULSION, EXCEPT OUTBOARD ENGINES, AMERICAN BOAT AND YACHT COUNCIL (ABYC) STANDARDS AND RECOMMENDED PRACTICES SHOULD ALSO BE FOLLOWED.

PANELTRONICS INCORPORATED IS A COMPANY COMMITTED TO TOTAL QUALITY AND CONTINUOUS PRODUCT RESEARCH, DEVELOPMENT AND IMPROVEMENT. THEREFORE ALL INFORMATION AND SPECIFICATIONS ON THIS DIAGRAM ARE SUBJECT TO CHANGE WITHOUT NOTICE.

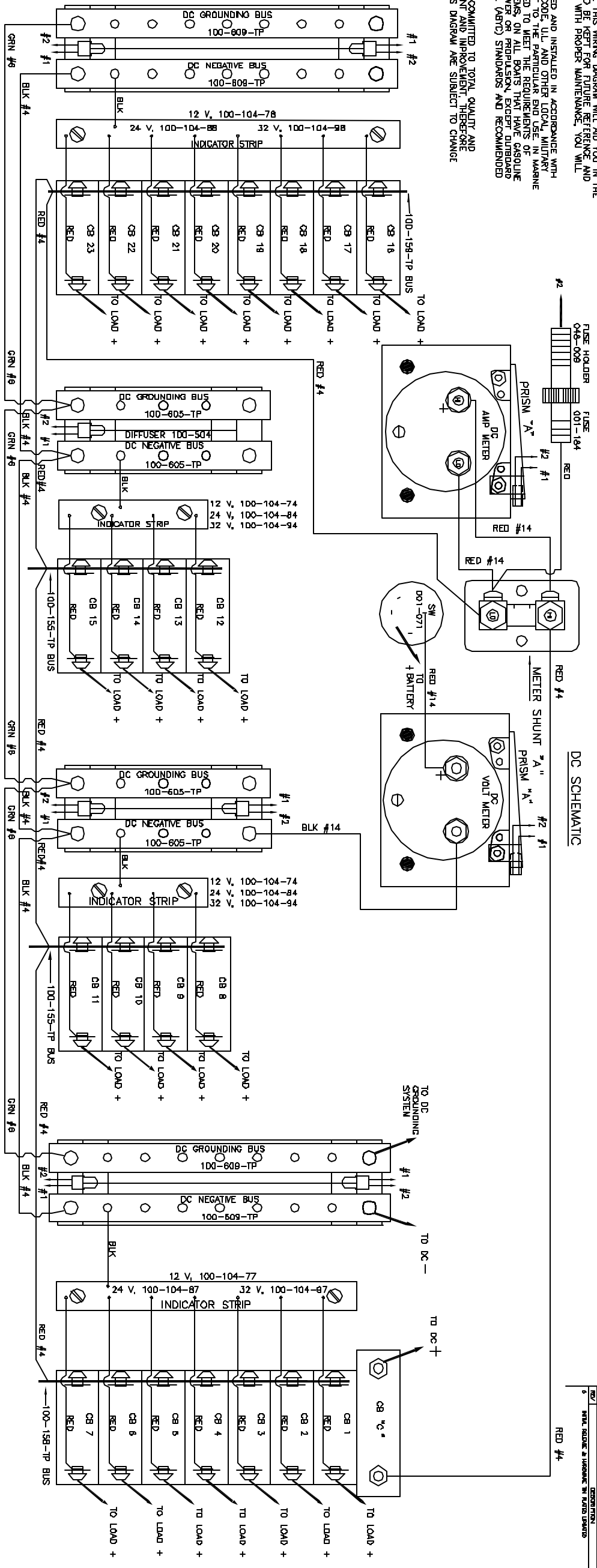

DC SCHEMATIC

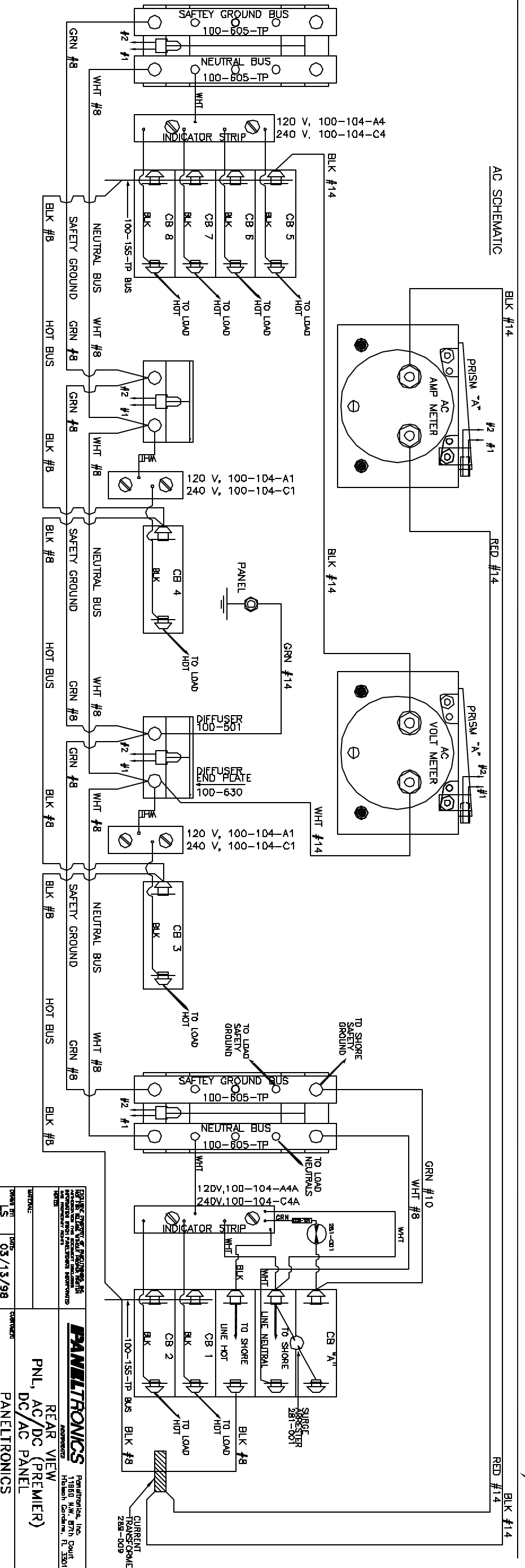

AC SCHEMATIC

DC MAIN	
RATING	PART NO.
50A	208-025
30A	208-026
15A	208-027
10A	208-028

SHORE MAIN	
RATING	PART NO.
30A	209-082
15A	209-083

METER SHUNT "A"	
RATING	PART NO.
50/250 MV	288-010
30/150 MV	288-011
15/75 MV	288-012
100/50 MV	288-013

DC "C"	
RATING	PART NO.
50A	208-025
30A	208-026
15A	208-027
10A	208-028

CB1 - CB31	
RATING	PART NO.
5A	208-075
10A	208-076
15A	208-077
20A	208-078
25A	208-079
30A	208-078
35A	208-079
50A	208-075

METER LUMINATION	
RATING	PART NO.
12 VDC	100-248-7
24 VDC	100-248-8
32 VDC	100-248-9

BACKLIGHT	
RATING	PART NO.
12 VDC	100-243-10
24 VDC	100-243-11
32 VDC	100-243-12

ASSY	
RATING	PART NO.
12 VDC	100-243-10
24 VDC	100-243-11
32 VDC	100-243-12

BACKLIGHT	
RATING	PART NO.
12 VDC	100-243-10
24 VDC	100-243-11
32 VDC	100-243-12

**PANELTRONICS** Paneltronics, Inc.  
17180 B. DRIVE  
HOLMDEL, CALIFORNIA, FL 33418

REAR VIEW  
PNL, AC/DC (PREMIER)  
PANELTRONICS

DATE: 05/13/98  
DRAWN BY: 288  
CHECKED BY: 1X  
SCALE: D  
CATEGORIES: CAT

4401